

# Green Audit Report 2022



**DAYANANDA SAGAR COLLEGE OF  
ARTS SCIENCE AND COMMERCE**  
SHAVIGE MALLESHWARA HILLS, KUMARASWAMY LAYOUT, BENGALURU



**DAYANANDA SAGAR**  
College of Arts, Science & Commerce



# VANALOK

environmental sustainability

4<sup>th</sup> Floor, Vanavikas, 18th Cross Malleshwaram,  
Bengaluru-560003, vanalok@gmail.com  
+91 9591100551 / 9449285226

7<sup>th</sup> March 2022

## CERTIFICATE

This is to certify that Dayananda Sagar College of Arts, Science and Commerce Bangalore has conducted detailed Environmental Green Audit of their campus and has submitted necessary data and credentials for scrutiny. The activities and measures carried out by the college have been verified based on the report submitted and was found to be satisfactory. The efforts taken by the faculty and students towards environment and sustainability is highly appreciated and commendable.

Director



Vanalok Private Ltd



Green Audit conducted By

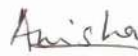

Anisha Udaykumar

21/IN/1022348/6032

# Acknowledgement:

We would like to acknowledge and give our warmest thanks to the Dayananda Sagar College of Arts, Science and Commerce - IQAC and Infrastructure Cell for their support and for providing us necessary facilities and co-operation during the audit process. This helped us in making the audit a success.

We hope this would help Dayananda Sagar College of Arts, Science and Commerce with their future endeavors and help them achieve all their environmental aspirations and vision.

- Vanalok Pvt. Ltd  
Vanavikas Building, 4<sup>th</sup> floor,  
18<sup>th</sup> cross, Malleshwaram,  
Bengaluru - 560055

# Executive Summary:

Nature encompasses fascinating inhabitants like microorganisms, plants, animals, insects, etc., who have as much right to live as we do. People all over the world see nature differently. With the climatic conditions going haywire all over the world, there is a need for resilient infrastructure, actions and a strong mindset for driving lifestyle change. Students being future citizens of the world can drive change and strive for a better existence and this would be possible only if educational institutions impart values and space for them to grow. They have also the ability to influence their families and the general public more effectively than even a learned motivator. Teachers play an undeniable role in imparting knowledge to the students. Hence, teachers are in a position to facilitate knowledge and promote the learners to achieve better awareness about what is happening in and around them. Teachers as professionals and influential individuals, supported by the management of institutions, can play an important role in shaping up students' attitudes through training and parading them - to be the role models in their communities. Educational Institutions thus can offer an ideal service in moulding the young minds in their impressionable age, towards promoting the health of nature, understanding the underlying causes of climate change and its impacts, and the conditions required to be maintained for sustaining life on earth.

Green Audit is, therefore to make the entire college and the society understand through the trained students, how heavy is their carbon footprint, and help search for remediation and make their campuses and living surroundings 'as green as one can make it'. It is also in search of newer ways to climb up the ladder through continuous efforts for the most sustainable ways of thriving.

The result of such an exercise would help their parents and other visitors to the campus in appreciating their responsible behaviour and admire the novel ways in which the campus team has strived to achieve their “shade of green”. A green audit can also be a useful tool for a college to know how and where they are using the most energy, water or other resources. The college can thus plan for the needed changes and ensure savings. It can also be used to improvise their waste minimization strategy. Green auditing and the implementation of mitigation measures will be a win-win situation for the college, the learners and the planet. It can also create health consciousness and promote awareness of the environment, ethics and values.

Eco-campus is a concept often used by educational institutions around the world to make campuses more sustainable by reducing wastages and enabling their safe disposal into the environment. Waste minimization plans for academic institutions are now mandatory to ensure that the campus is cleaned regularly. As an eco-campus, performing a green audit of the university is critical. The green auditing of Dayananda Sagar College of Arts, Science and Commerce in Bengaluru allows the assessment of lifestyle, actions, and their impact on the environment. The audit was primarily focused on greening factors such as energy consumption in terms of electricity, water management, waste management, and green spaces management. A series of methods were used to obtain information about the green practices of the college. A set of questions were formulated, reports and documents were verified and a series of interviews were conducted with people in charge of each criterion to ensure the accuracy of information. The information gathered was organized, tallied, and analyzed. Finally, a report on environmental observations and recommendations for improvement were listed out for the perusal of the management.

# Table of Contents

**Acknowledgement:**..... 1

**Executive Summary:**..... 2

**1. Introduction:** ..... 5

**1.1. Need for Green Audits:**..... 6

**1.2. Goals of Green Auditing:** ..... 6

**1.3. Objectives of Green Audit:**..... 7

**1.4. Benefits to Educational Institutions:** ..... 7

**2. Scope of Green Audits:** ..... 7

**3. About the College:**..... 8

**4. Observations and Recommendations:**..... 11

**4.1 Energy Management:** ..... 11

**4.2 Water Management:** ..... 14

**4.3 Waste Management:** ..... 16

**4.4 Green Spaces Management:**..... 19

**5. Summary:** ..... 21

**6. Corollary:**..... 22

# 1. Introduction:

Green audits help analyse local environmental practices both inside and outside the university premises that influence the atmosphere of the campus. Therefore, ‘Green Audits’ can be defined as a systematic, identification, quantification, recording, reporting and analysis of components that constitute a university environment. Through such audits, the current status, scope for improvement, and recommendations for improvement can be made available which would further improve the structure of the environment and enhance the efficiency and atmosphere of the campus.

A green audit also serves as a means to identify opportunities for sustainable development practices, enhance environmental quality, improve health, hygiene and safety, reduce liabilities and save money and achieve values of virtue.

Green audits are assigned to criteria 7 of the National Assessment and Accreditation Council, which is a self-governing organization that provides various institutions with grades based on their criteria for accreditation. This accreditation provides a college with an opportunity to present itself as an esteemed institution without impeccable values, infrastructural advantage and endless opportunities it could provide its students.



## **1.1. Need for Green Audits:**

Green audits help analyse and determine good institutional practices; whether they are eco-friendly or sustainable. With the world constantly changing, development, unfortunately, results in large-scale utilization of natural resources. Now natural resources are not just used for the supply of products. Energy, water are all basic commodities that are used generously by all. With the threat of depleting resources looming over our heads, it is imperative to determine how much we use and where we waste resources to ensure efficient usage. Green audits provide opportunities to determine the same and help the organization to reflect, improve and expand their processes and shift to clean green resource utilization. Apart from this, it helps instil consciousness among people as part of the institution towards the environment and sustainable resource utilization.

## **1.2. Goals of Green Auditing:**

- a) Identification of strengths and weaknesses in green practices.
- b) Analyse and suggest solutions for problems identified.
- c) Identify and assess environmental risk.
- d) Motivate staff for optimal sustainable use of available resources.
- e) Increase environmental awareness throughout the campus.
- f) Collect baseline data of environmental parameters and prepare plans for issues before they become problems.



### **1.3. Objectives of Green Audit:**

- a) Analyse current practices and determine their impact on the environment.
- b) Identify and analyse significant environmental issues.
- c) Continuous assessment for better environmental performance.
- d) Establish and implement a green culture on the campus and sensitize the faculty and students.

### **1.4. Benefits to Educational Institutions:**

- a) Improve the environment within and outside the campus premises.
- b) Help recognize cost-effective green strategies like waste minimization, energy conservation, water replenishment etc.
- c) Empower people linked to the organization to move towards conscious environmental thinking and practice.
- d) It helps improve the image and builds a positive impression of the institution for its green and clean approach.

## **2. Scope of Green Audits:**

The benefits of green auditing practices are the following:

- a) Environmental education through systems thinking and environmental management system approach.
- b) Benchmarking for environmental protection initiatives.
- c) Financial savings through efficient resource use.
- d) Enrichment of curriculum through hands-on experiences.
- e) Enhancement of college profile and improving environmental standards.
- f) Strengthening the environmental ethics and value systems in young people.
- g) Developments of ownership, social and personal responsibility for the campus and its surrounding environment.

### 3. About the College:

Dayananda Sagar College of Arts, Science and Commerce (DSCASC), is one of the oldest degree colleges in Bengaluru, run under the Dayananda Sagar Institutions. It is affiliated to Bangalore University. The college runs abiding the vision of their late founder, Sri Dayananda Sagar's visionary outlook of 'Live the Dream'. The college holds a legacy of creating many outstanding individuals who have delivered their contributions to society in various fields. As a contemporary leader in the realm of education and being one of India's esteemed institution, Dayananda Sagar Institutions operate under the aegis of Mahatma Gandhi Vidya Peetha Trust.

The institution's philosophy is to blend individual academic brilliance with holistic development. The students are provided with finest qualitative education in a challenging academic atmosphere to introduce growth under the nurturing guidance of the faculty. With an emphasis on developing the critical thinking skills of students and transform them into socially progressive and responsible individuals who move the world with their compassion and skills, the students in DSCASC are guided to reach their full potential through a cultural and scientific pedagogical strategy designed for holistic growth. The environment in the campus is such that, freedom of thoughts and conversations encourage students to discover and explore a wide range of possibilities presented to them during the course of their study.

In this regard, students are provided with well-equipped lecture halls and laboratories to explore theory in practice, libraries to enhance their knowledge, computer facilities along with a high-quality teaching faculty.

There also opportunities for doctorate and post-doctoral research within the campus. Apart from academics, an outstanding sports and recreational facility is presented to the students. Outside classrooms students have safe hostel facilities to both local and international students with provisions for modern cafeterias that address their nutritional needs. The institution has mindfully provided sufficient space for all the essential requirements of the student, such as bicycle parking, proper roads, a sitting area, well-maintained washrooms, clean filtered drinking water, good playgrounds and well-managed green space. The corridors are clean with provisions for dustbins and lights wherever necessary are present. These amenities reflect the institution's mission to focus on the overall development of the student as a responsible, intellectually awake and creative citizen who grows with mutual understanding and solidarity thereby moulding them into ethically sensitive future leaders.







## 4. Observations and Recommendations:

### 4.1 Energy Management:

Energy conservation is an important component of campus sustainability, as it is linked to the institution's carbon footprint. Energy auditing primarily is associated with energy conservation and techniques for reducing consumption that contributes to environmental degradation. As a result, any environmentally conscious institution must evaluate its energy usage policies. This indicator addresses energy consumption, energy sources, energy monitoring, lighting, appliances, and vehicles. Energy use is an important aspect of campus sustainability and thus requires no explanation for its inclusion in the assessment.

Sl No.	Load	Numbers
1	DG set	Kirloskar (400 KV-1, 250 KV - 2) 3 phases; 80% Load
2	Lights	345 - LED
3	HV AC system	Fans – 249 AC – 5
4	Motors	Borewell – 8 Lift – 1 (7.5hp)
5	Electronic Equipment: <ul style="list-style-type: none"> <li>Laptops</li> <li>Desktops</li> <li>LCD Projectors</li> <li>Printers</li> <li>Photocopiers</li> </ul>	6N 311N 39N 18N 3N
6	Solar Panels: EU Block PUC Block  Energy generated	300 185  2, 020,256 KWH/ Year

## Observations:

Energy is one resource that is used in every branch of the institution. The primary source of energy is electricity and the total energy consumption for the FY 2021-22 is 95508.16 units/year respectively. Apart from this, there is a provision for a generator for emergencies. The college has also installed a series of solar cells on their terrace thereby utilizing the vacant space for energy generation using the sun's rays. All the energy generated is directly sent to the local power supply body KEB thereby receiving a subsidy in their regular bills and offsetting the energy used by giving back energy. The total energy generated by the solar set up is 2020256 KWH/year with 300 panels in the EU block and 185 panels in the PUC block. Apart from this, the CFL bulbs are being changed to LED in a phased manner thereby reducing consumption to almost half of what CFL bulbs would have consumed. The college authorities have taken time to review and track their lighting opportunities in order to utilize natural lighting and ventilation where ever possible. The screens are drawn during the summers to block out the heat and open during cooler climate to keep in the heat. The college also runs a "switch-off drill" and strictly follows a system of switching off all appliances after occupancy time. Computers are mainly used in the UG and PG courses and all run-on power management settings with disabled screensavers.



## Recommendation:

- Foot valves shall be used to automatically switch off the water supply when the tank reaches optimal levels. This could help save both energy as well as water. Automatic bore well management systems with sensors at the overhead tank as well as underground would help pump water only in case of shortages.
- Using Brushless Direct Current Fans could help reduce the consumption by half. All traditional electric appliances shall be replaced with energy-efficient ones to reduce power consumption and wastages.
- Lighting in some areas such as the toilets can be controlled by PIR (passive infrared light) sensors.
- Holding power conservation and awareness events could help keep the college community engaged.
- Existing UPS system needs to be upgraded to smart UPS system which will help the institution to save energy.





## 4.2 Water Management:

Water is an important resource that is depleting at a rate faster than what can be recovered. All beings depend on water for their survival. Although the earth is covered by water majorly, freshwater that is used for drinking purposes is very limited. Hence, it is very important to use water judiciously and make arrangements to collect and preserve water whenever possible for replenishment of the water table. This indicator addresses water consumption, water sources, irrigation, stormwater, appliances and fixtures. A water audit is an on-site assessment and surveys to determine the practices and efficiency of usage.

### Observation:

The major source of water supply are campus borewells and water from rainwater harvesting. Everyday pumps are operated to fill the overhead tanks (56) with capacities of 500, 1000, 2000 & 5000 litres. The tanks have a system of automatic water level controllers to ensure limited wastages. Water is majorly used in washrooms, canteen, administrative areas, academic areas, hostels and gardening purposes. The management has made available provisions for purified drinking water on campus for the students and other staff. Wherever applicable the washrooms have aerators installed in the fittings to ensure minimum wastage of water.

During the survey, no wastages were observed. The open grounds provide means for water percolation as they are not barren due to ample greenery on campus. The campus has a functional rain water harvesting unit and the water collected is used for campus needs. All the waste water from the campus is treated by a fully functional Sewage Treatment Plant and is reused for gardening purposes in the college.



## Recommendations:

- Push Button taps can be implemented phase wise in wash rooms to prevent water wastage.
- Rainwater harvesting units can be improved in the premises to conserve rainwater run-off and recharge pits can be employed close to the borewells or wells to help recharge the groundwater table.
- Minimizing wastages by reducing, reusing and recycling wherever possible.
- Installation of low flow faucets, shower heads and fittings to reduce wastage and consumption. Automated taps could also help reduce usage.
- Fix leaky faucets and flushes regularly.
- Ensure all disinfectant products used are eco-friendly and do not cause major harm to the environment.



### 4.3 Waste Management:

Solid waste can be categorized into three types namely: Biodegradable, Non-Biodegradable and Hazardous Waste. In an institutional setting, the only hazardous waste generated is E-waste and Sanitary Waste. Biodegradable or Wet waste is mainly leftover food components, canteen waste etc., while non-biodegradable includes recyclable waste like plastics, tin, bottles, papers etc. E-waste majorly contains harmful chemicals and metals that could cause harm to the handlers or even cause harmful gas emissions in case it is burnt in landfills. Such waste needs to be collected and given special treatment. Thus, minimization of solid waste is an essential win on the road to sustainability. This indicator addresses the waste collection and disposal mechanisms.

#### Observations:

The total waste collected on the campus comprises of wet waste and dry waste. Waste segregation seems to be taking place at the source itself. There were provisions for dustbins with clear demarcations for wet waste and dry waste in every place possible. All the segregated waste are sent to the respective vendors. Wet waste is sent to piggeries, dry waste to recycling units and E-Waste to the respective authorized vendors who would safely dispose of the waste components after extraction of required materials. The institution encourages extensive usage of E-communication thereby moving towards a paperless mode of communication. The college has a fully functional STP (Sewage Treatment Plant) with a capacity of recycling up to 180KLD that takes care of all the grey water recycling. The water first passes through a collection tank with a bucket screen that screens solid waste initially. Following which the water is moved to an equalizer tank and then to an anaerobic digester used for treatment of wastewater. After the digestion of waste using microbes, the water is moved to an aeration tank that provides a constant supply of oxygen to allow the microorganisms to digest the organic waste. The water is then moved to a clarifier tank to allow the sludge to settle at the bottom. The recycled water is sent to filtration units to further process the water and then finally sent to the collection tank. The recycled water is then utilized for gardening purposes. A thorough STP plant is necessary as the lab waste and other sewage needs to be thoroughly treated. The presence



of this impeccable recycling option in the campus definitely shows that the opportunities for waste water utilization is fully explored.

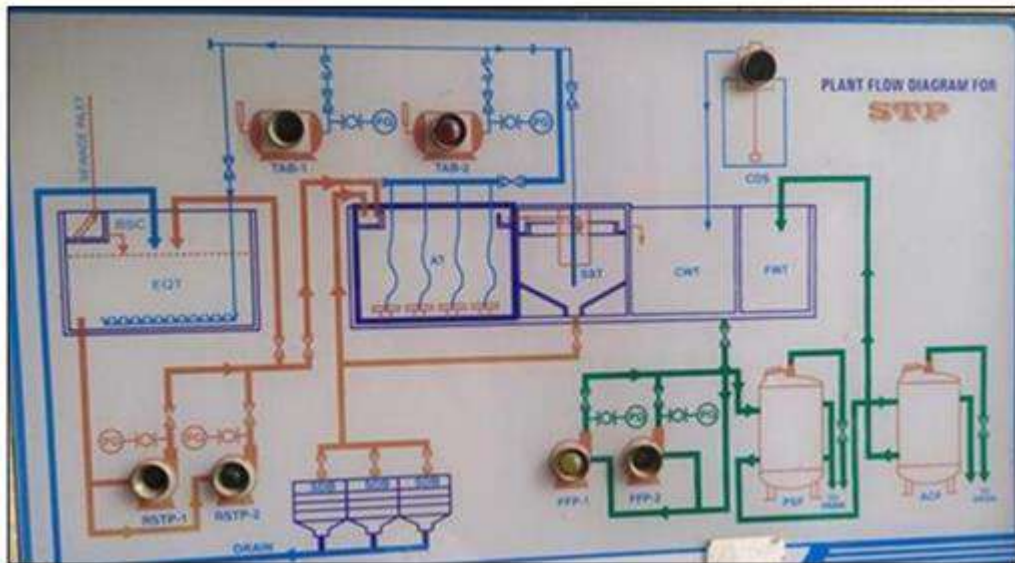

## Recommendations:

- Having proper sanitary waste disposal mechanisms on site like an incinerator for safe disposal could be beneficial in the longer run. Having sanitary pad machines could also benefit the students on campus.
- Apply concepts of Reduce, Reuse, Recycle and Refurbish wherever possible.
- Install proper composting units in the form of pits to take care of wet waste in the premises itself. This could be done involving students and the compost could be used as nourishment for the trees and plants on the campus.
- Training and campaigns in cotton bag making for students and staff will reduce the usage of throw away plastic carry bags.
- Leaf litter from the campus can be effectively used for aerobic/vermicomposting so that the composted material can also be used as good manure.



## 4.4 Green Spaces Management:

With the rapid increase in urbanization, the availability of green spaces for recreation and relaxation is slowly reducing leading to detrimental repercussions on student growth and health. Students need to grow and learn in environments that promote their physical health as well as their cognitive development to enhance their academic learning. Green spaces boost mental health among adults and can offset traffic emissions. Greenery can help reduce air pollution in several ways like filtering air, restoring water tables, reducing heat island effects and reducing noise levels.

### Observations:

Dayananda Sagar college boasts a good amount of greenery with a good number of species of trees on the premises. The students have an established Environment Club that conducts activities to sensitize and spread awareness within the student community. They undertake responsibilities to care for the campus cleanliness.

A big portion of the student community as well as the teaching and non-teaching staff use eco-friendly modes of transport.

**Indoor Plants:** A study published in the Journal of Physiological Anthropology found that indoor plants can bring a great difference in the reduction of stress levels and help provide comfort and sooth minds. It improves the overall mental well-being of students and help them concentrate and focus better in classes. They also improve the indoor air quality and improve outlook towards their work and life.

## List of students who travel to college by respective mode of transports:

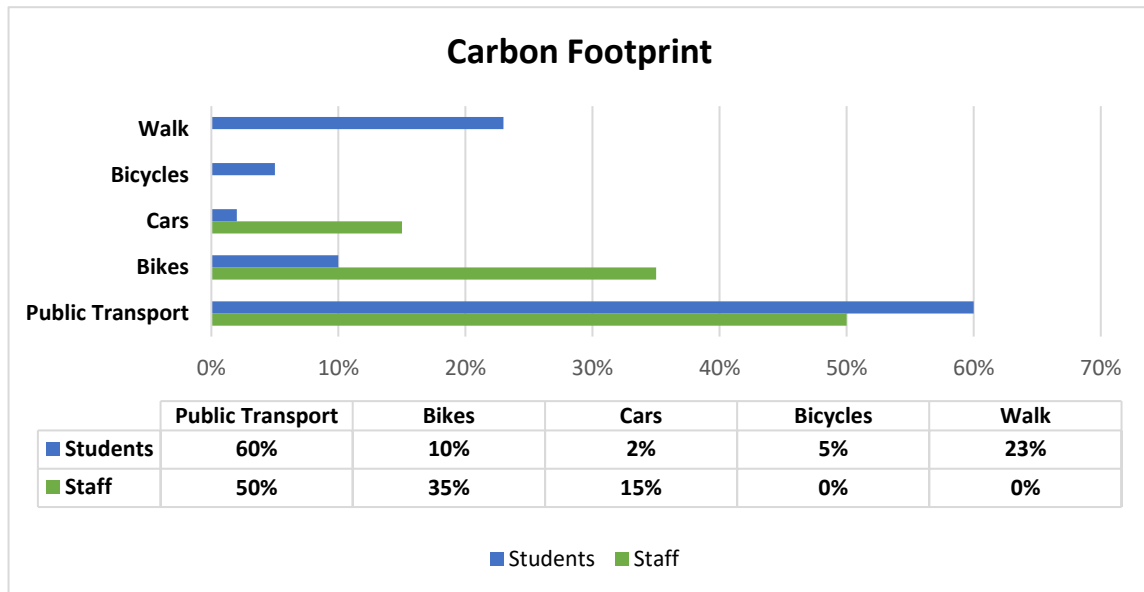

## Recommendations:

- Keep records of the trees and plants on the campus and lookout for opportunities to increase their number.
- Try involving students to care for gardens and composting within the college premises.
- Include environmental sciences as an added subject in the curriculum for at least one module.
- Include opportunities for students to volunteer and be a part of environmental organizations by incentivizing the same for extra credits.
- Include projects that involve environmental concerns and what students can contribute from their respective fields as a part of the curriculum to enhance problem-based thinking capabilities.



## 5. Summary:

An audit of natural resources is an important tool for ensuring that natural resources are being used in an eco-friendly and sustainable manner. Green auditing is the process of determining whether institutional practices are environmentally friendly and sustainable. It is a continuous process of identification, monitoring and discussion. There is scope for further improvement, particularly concerning waste, energy and water management. The college in recent years consider the environmental impacts of most of its actions and makes a concerted effort to act in an environmentally responsible manner. Even though the college does perform fairly well, the recommendations in this report highlight many ways in which the college can work to improve its actions and become a more sustainable institution.



**Figure 1: Good Environmental Practices for Sustainable Development.**

## 6. Corollary:

From the green audit, the following conclusions can be made:

- ❖ Water management consists majorly of the rainwater harvesting systems that bring in a good amount of water that is used for gardening purposes. More thought could be put into rainwater recharge pits that could replenish the water tables.
- ❖ Food waste or wet waste, in general, can be turned into compost that can be used as enrichment for the green on the campus. This would help them institution lessen its dependence on the local authorities for disposal.
- ❖ E-waste is segregated, handled and disposed of properly in an eco-friendly and responsible manner.
- ❖ Reduction in the use of one-time-use plastics like bottles, cups, folders, pens and other decorations could help reduce the plastic waste menace on the campus.
- ❖ Almost the entire campus uses eco-friendly mode of transport.
- ❖ Wear masks signage were seen on the campus.